

MAIN LEVER 1 REQD STEEL

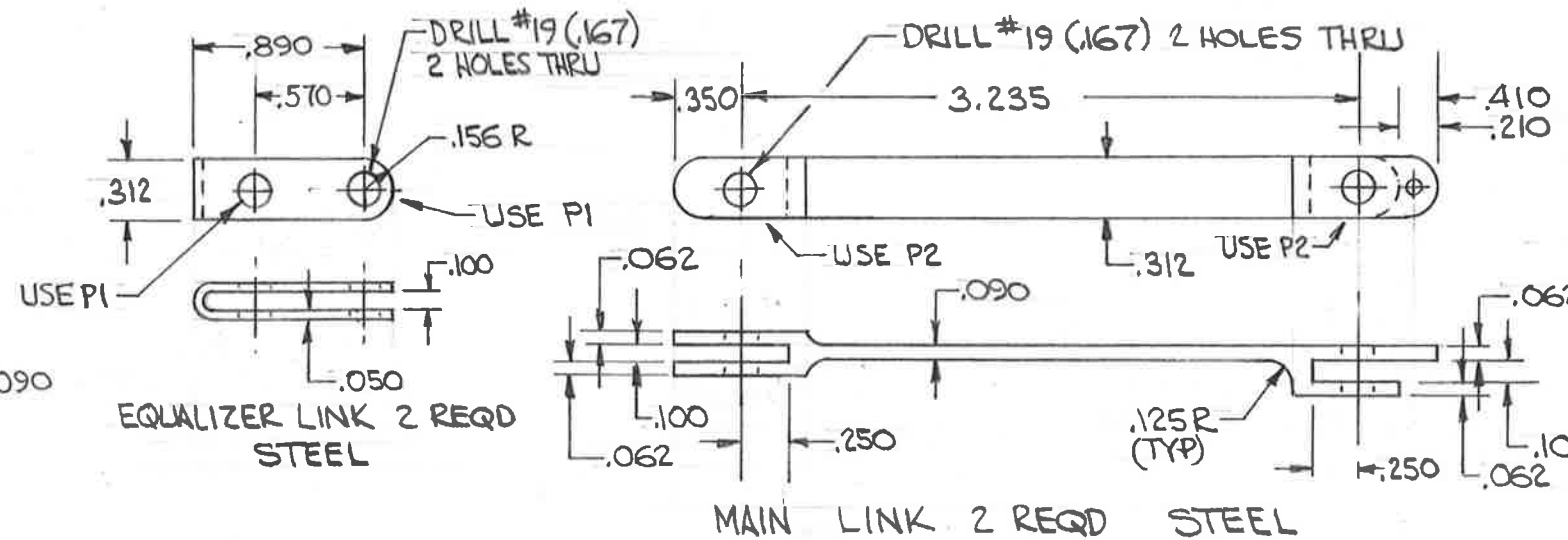

EQUALIZER LINK 2 REQD STEEL

MAIN LINK 2 REQD STEEL

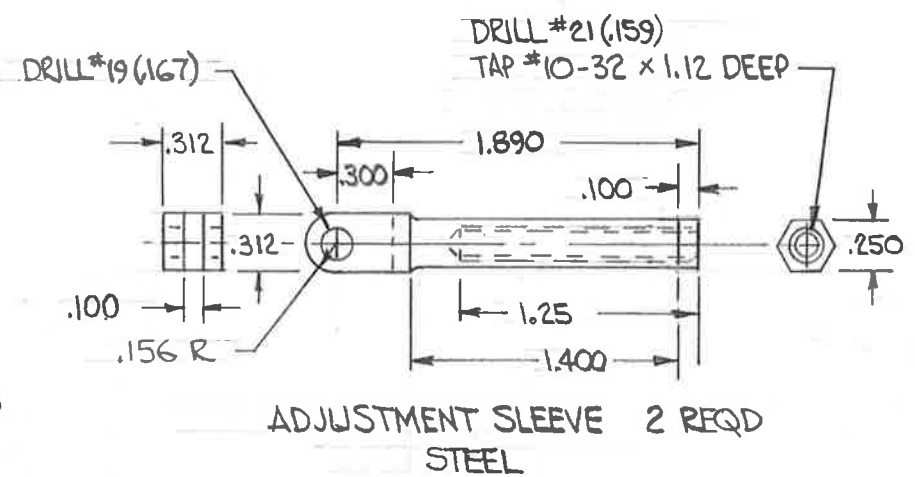

ADJUSTMENT SLEEVE 2 REQD STEEL

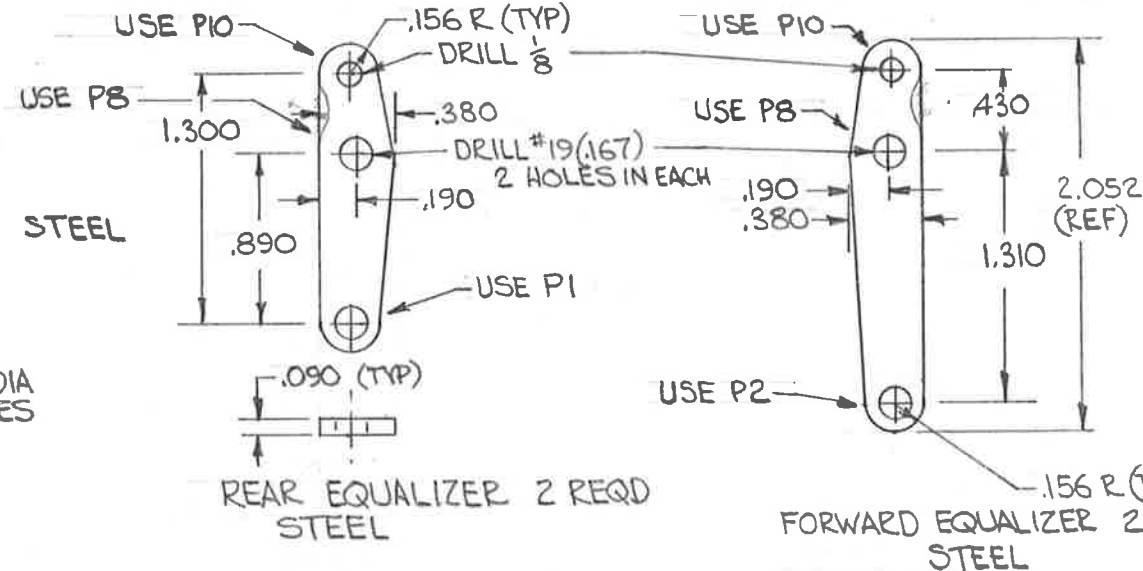

REAR EQUALIZER 2 REQD STEEL

FORWARD EQUALIZER 2 REQD STEEL

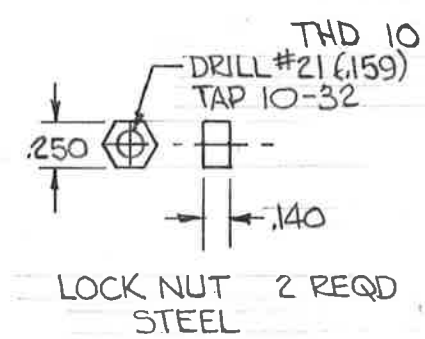

LOCK NUT 2 REQD STEEL

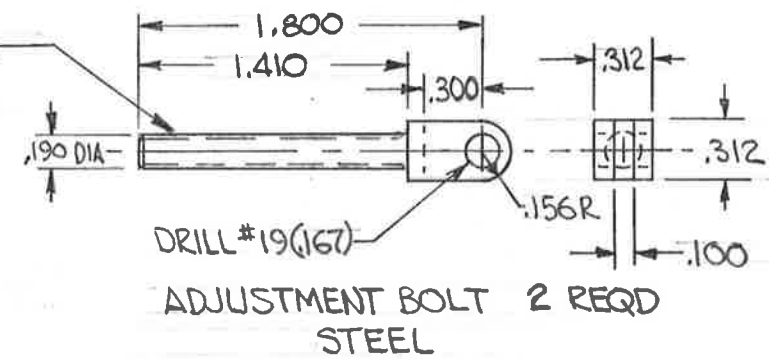

ADJUSTMENT BOLT 2 REQD STEEL

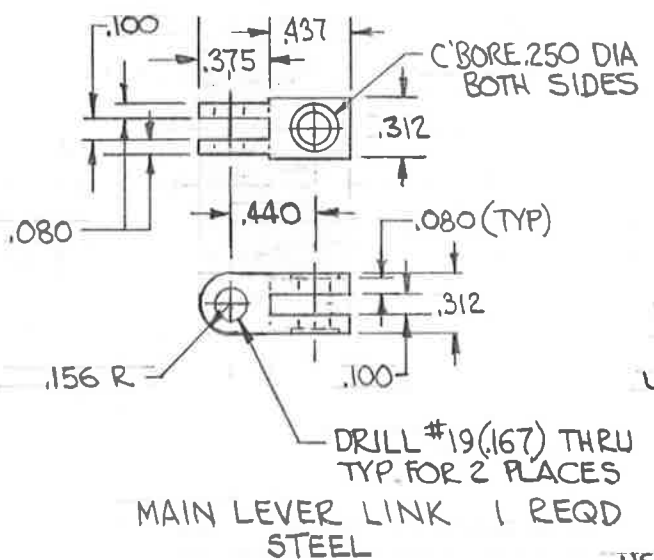

MAIN LEVER LINK 1 REQD STEEL

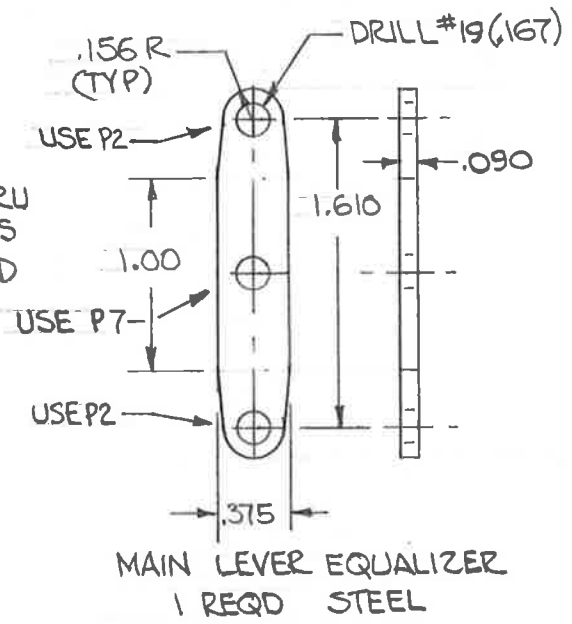

MAIN LEVER EQUALIZER 1 REQD STEEL

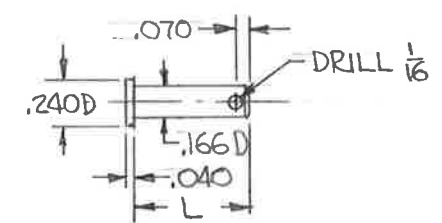

PIN 303 ST STEEL
SEE CHART FOR REQMTS
L = GRIP + .112

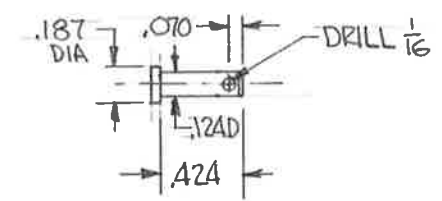

PIN P10 4 REQD

BRAKE LINKAGE PINS

NO.	"L"	NO. REQD	LOCATION
P1	.312	4	REAR EQUALIZER INBOARD, LINK ANCHOR
P2	.337	4	MAIN LEV. EQUAL ENDS, MAIN LINK FWD ENDS
P3	.362	1	BRAKE PISTON ROD END
P4	.372	1	MAIN LEVER BOTTOM
P5	.382	4	BRAKE SHOE PIVOT
P6	.396	1	MAIN LEVER CENTER
P7	.404	1	MAIN LEVER LINK (FWD)
P8	.424	4	FWD & REAR EQUALIZER CENTER
P9	.522	4	BRAKE SHOE PIVOT LINK UPPER

P-7 LEAD TRUCK BRAKE DETAILS
I.D. ALKIRE 1964