

Castings and
WW 4-6-0.
also avail-
rther infor-

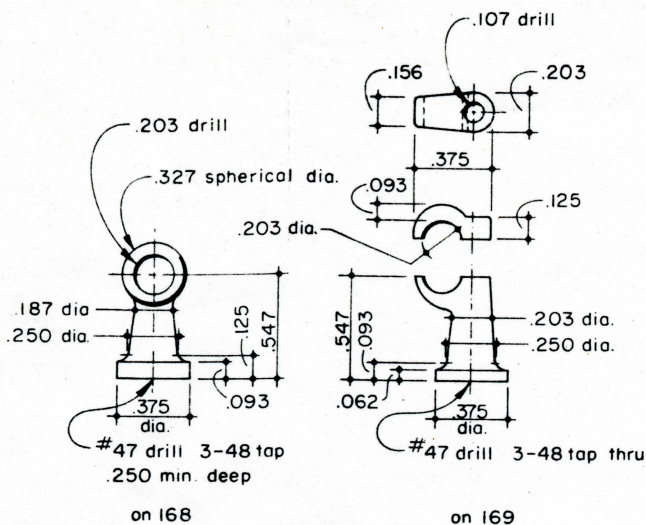

314 SHORT HANDRAIL STANCHION
Brass
2 Required

No. Req'd.	Description
23	#2-56 x 1/8 Model RO Hd Screws
23	#2-56 Model Hex Nuts
4	#3-48 x 1/4 Mach. Screw
4	#3-48 x 1/2 Thd. Rod
4	#3-48 Model Hex Nut
2	#3 Washer
6	#4-40 x 3/8 Model Hex Hd Screw
13	#4-40 Model Hex Nut
5	#5-40 Model Hex Nut

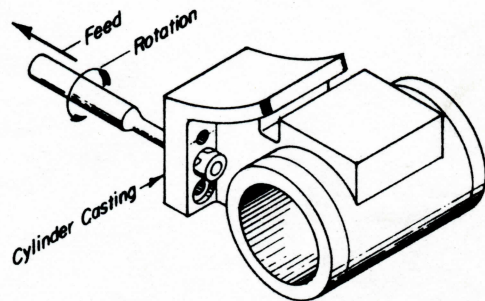

Sketch of
BACK SPOTFACING CUTTER
assembled on mandrel
in cutting position

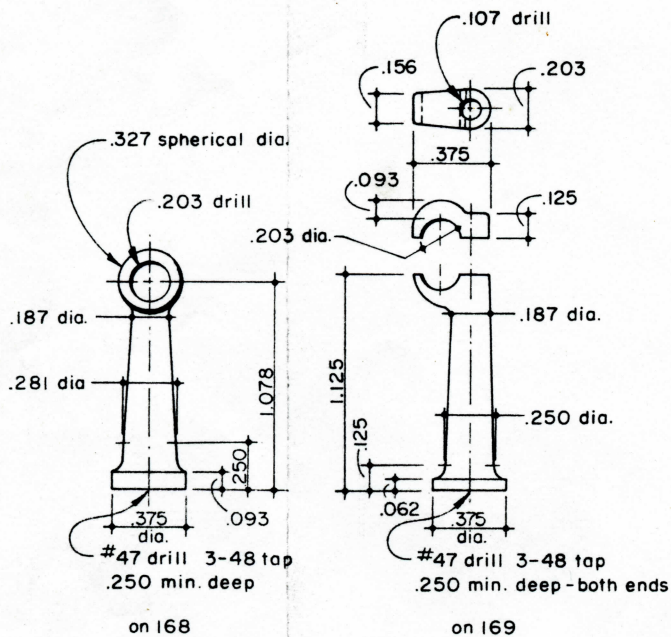

316 LONG HANDRAIL STANCHION
Brass
2 Required

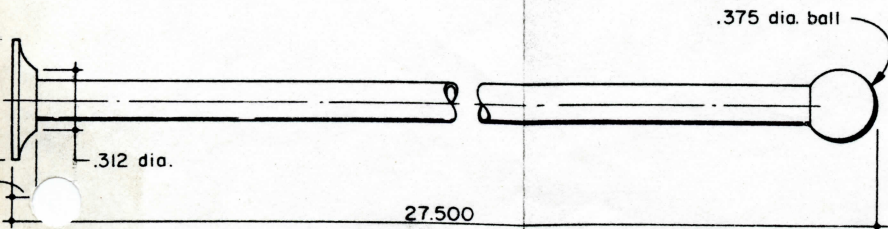
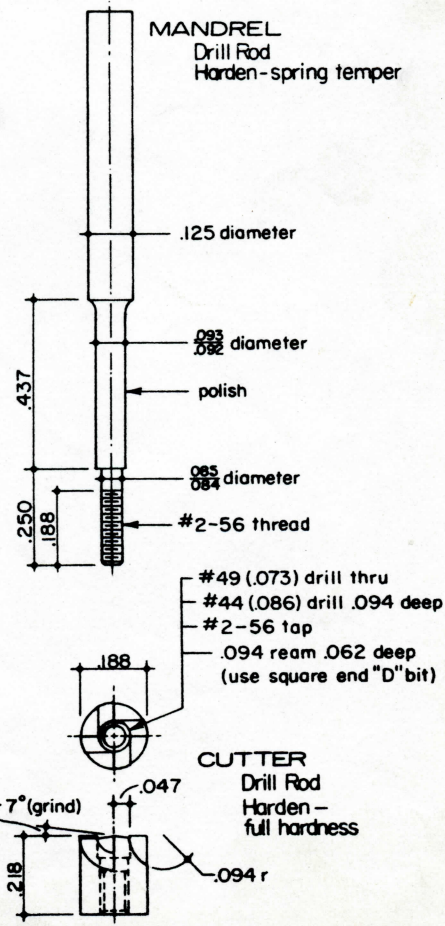

382 HANDRAIL
.187 O.D. Tubing
2 Required

rod screw (23 required)
required)

red

cket

il stanchion