

175 LINK BLOCK
Cold Rolled Steel
2 Required

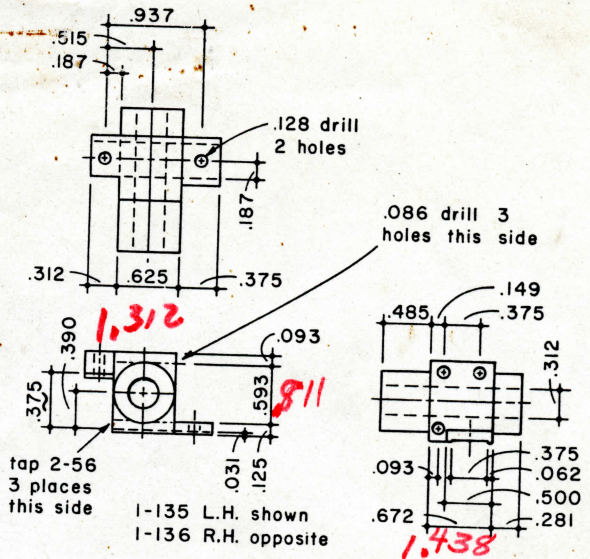

135, 136 ROCKER BEARING
Brass
2 Required

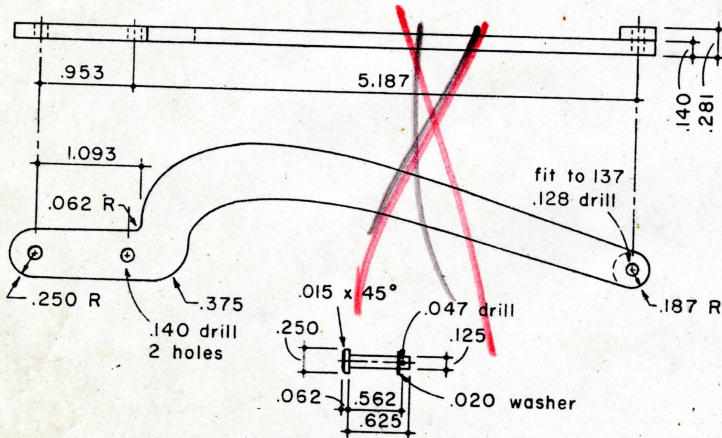

192 TRANSMISSION BAR
Cold Rolled Steel
2 Required
(1 as shown)
(1 opposite)

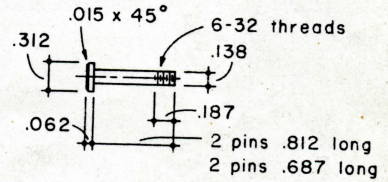
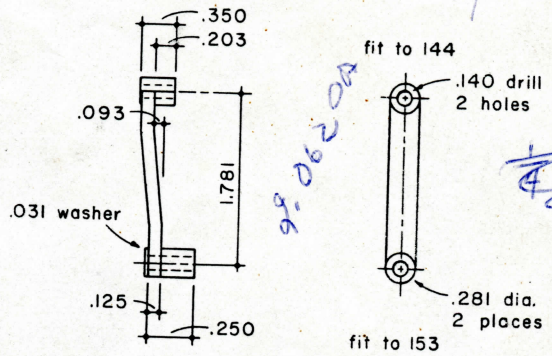

204 VALVE LINK HANGER
Cold Rolled Steel
2 Required

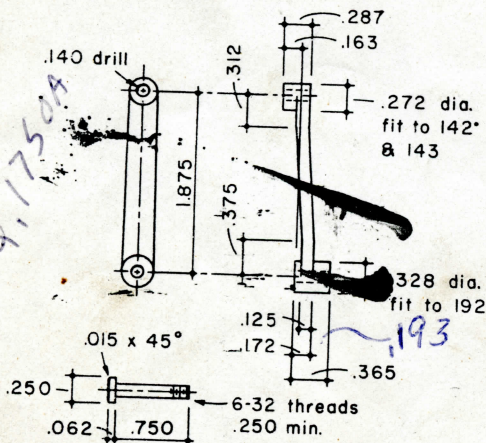

152 TRANSMISSION BAR HANGER
Cold Rolled Steel
2 Required

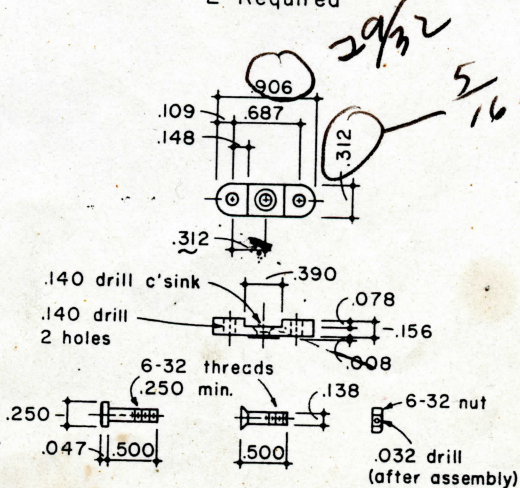

153 LINK SADDLE
Cold Rolled Steel
2 Required