

100 REAR ROD
Cold Rolled Steel
2 Required: (1 as shown, 1 opposite)

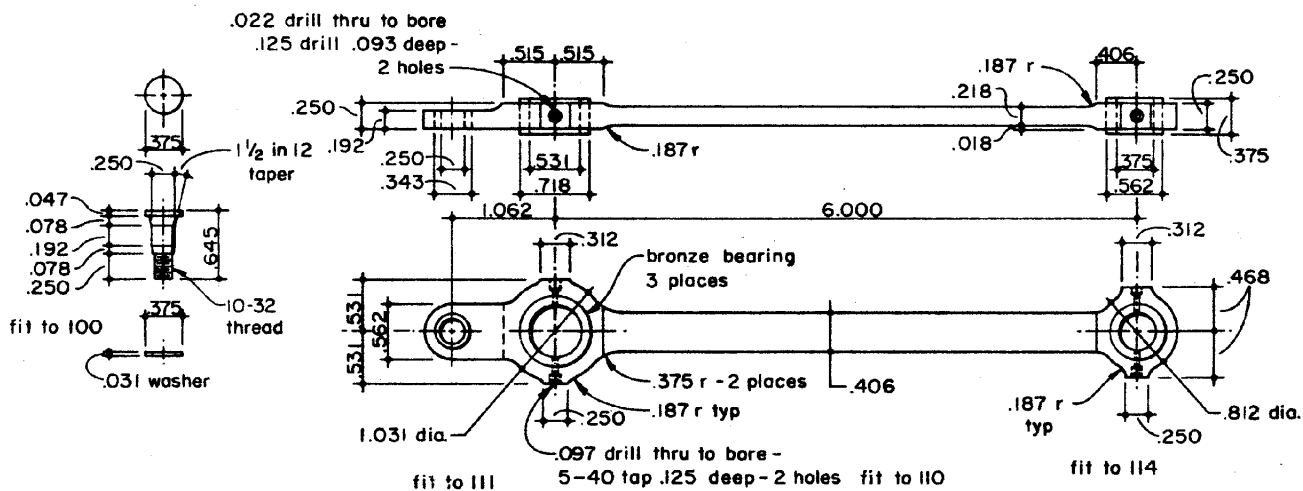

211/212 FRONT ROD
Cold Rolled Steel
2 Required: (1 as shown, 1 opposite)

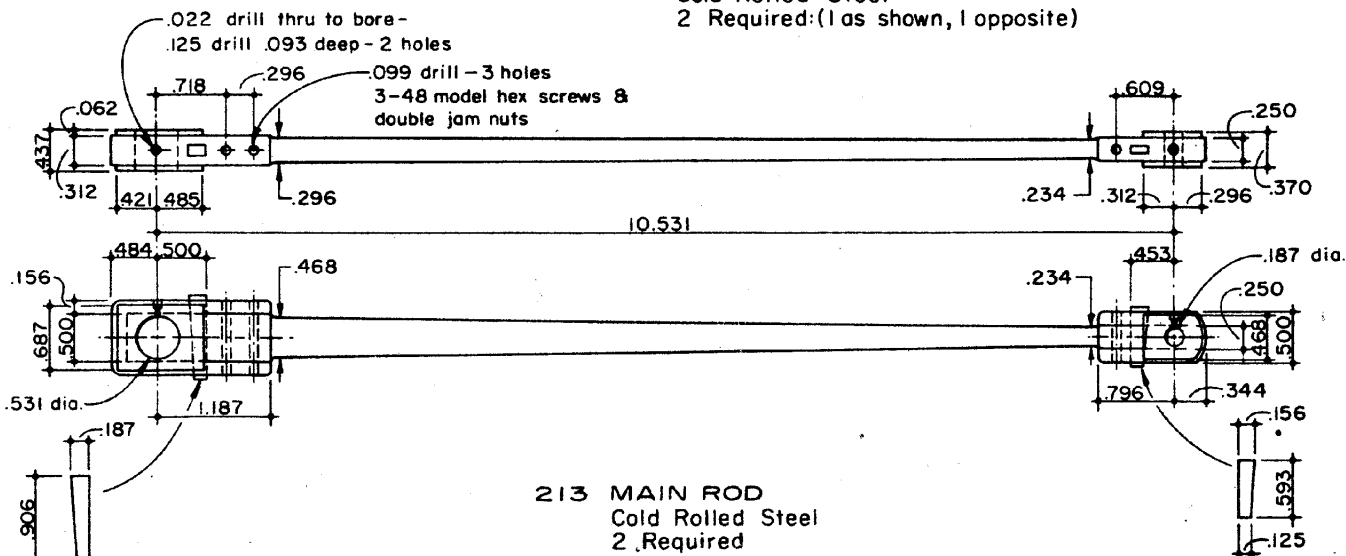

213 MAIN ROD
Cold Rolled Steel
2 Required