

595  
206

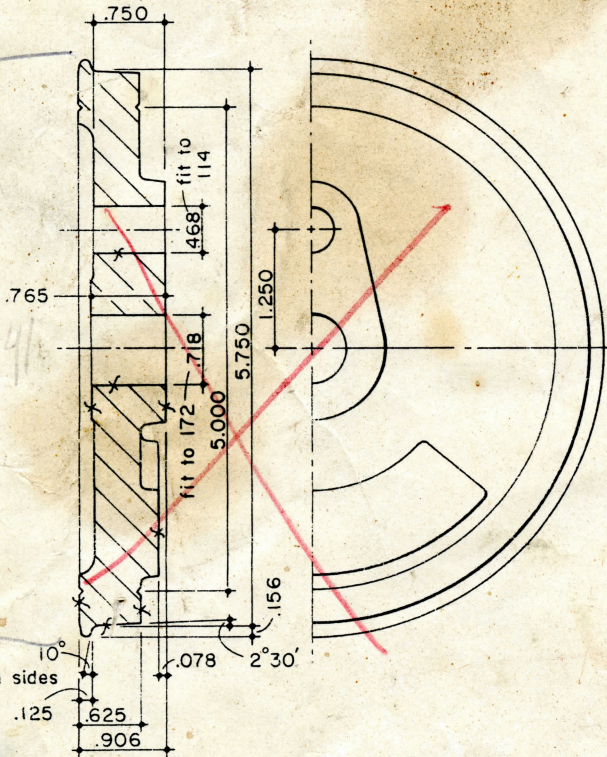

129 FRONT & REAR DRIVER  
Gray Iron Casting  
4 Required

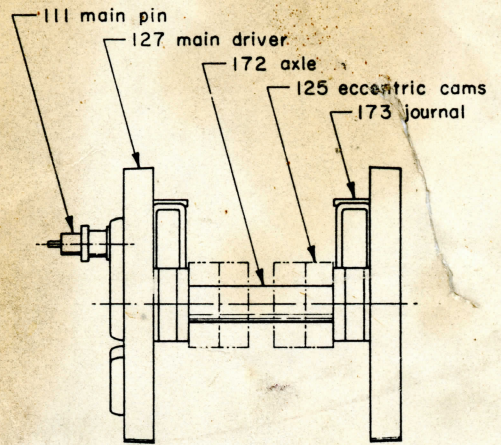
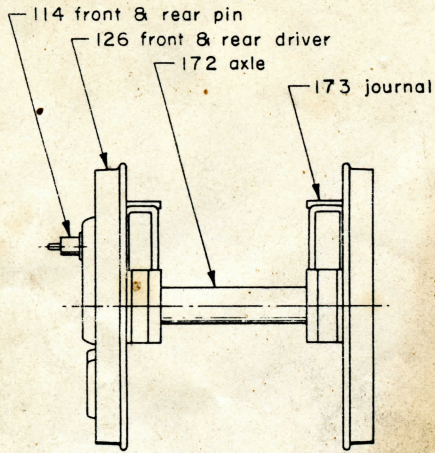
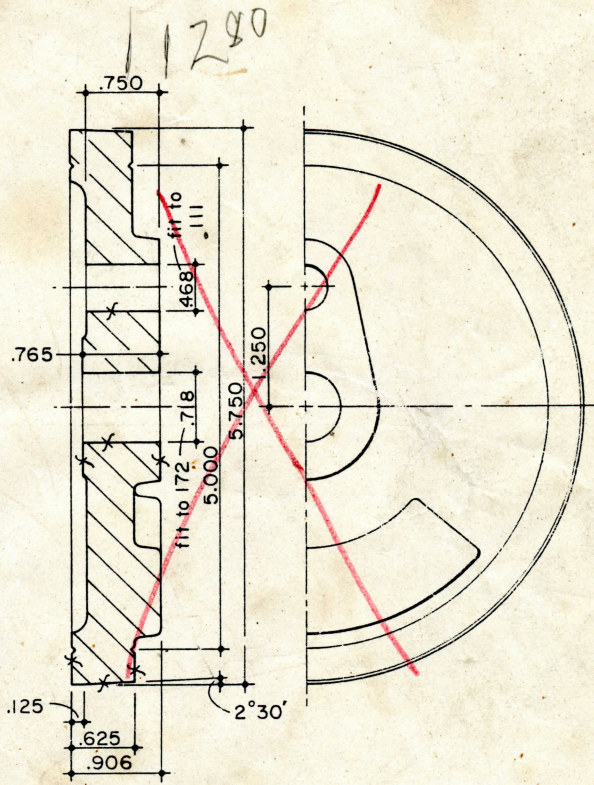

127 MAIN DRIVER  
Gray Iron Casting  
2 Required

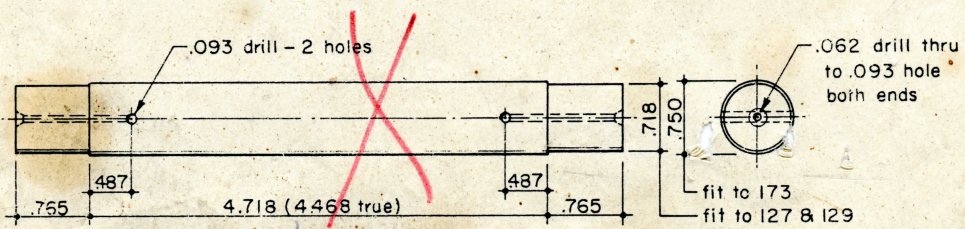

6.248  
172 AXLE  
Cold Drawn Steel  
3 Required