

110 BEARING STOP SCREW
Cold Drawn Steel
8 Required

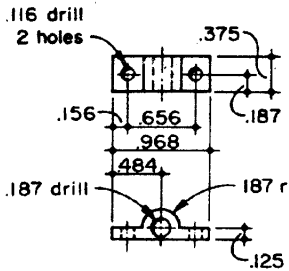

115 SHAKER SHAFT BEARING
Cold Rolled Steel
2 Required

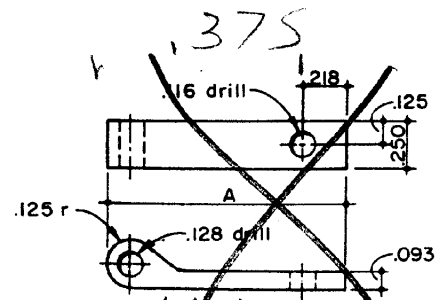

149 R.H. SHAFT BEARING (A=.593)
150 L.H. SHAFT BEARING (A=1.250)
Cold Rolled Steel
1 Each Required

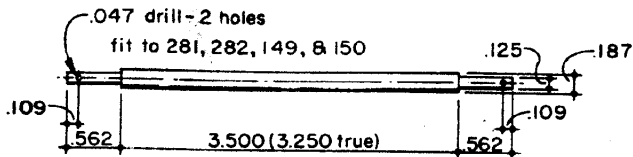

282 DRIFTER CROSSOVER SHAFT
Cold Rolled Steel
1 Required

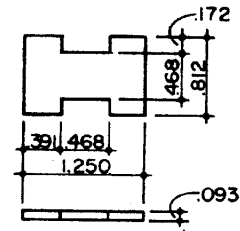

371 GUIDE
C.R.S.
6 Required

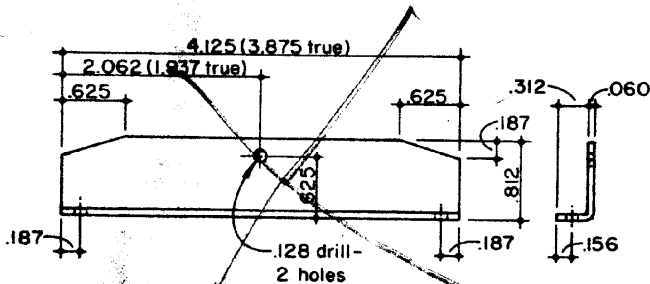

375 SPRING MOUNT
Cold Rolled Steel
1 Required

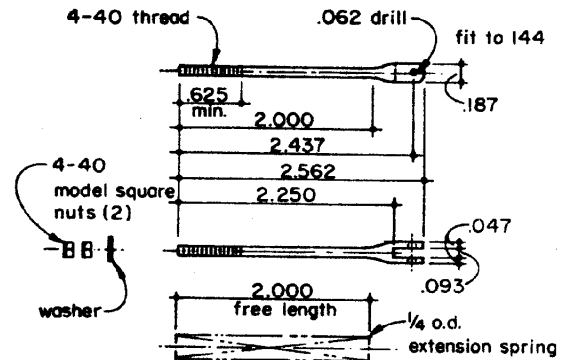

376 SPRING GUIDE
Cold Drawn Steel
1 Required

ALLEN MODELS

INCORPORATED

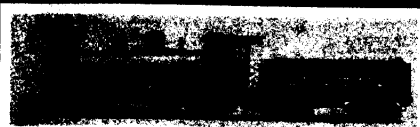

1 1/2" Scale Ten Wheeler
1 1/2" Scale WABASH Mogul
1 1/2" Scale American
2 1/4" Scale Plantation "Chico"



PHOTOS SPECIFICATIONS

OF MANY LOCOMOTIVES BUILT BY LIMA

SEND FOR LISTS:
SHAY GEARED LOCOMOTIVES - \$2.50

SPECTACULAR SAVINGS

HOBBYIST LATHES

- Prices from \$279.00
- Freight Allowances
- Free Brochures

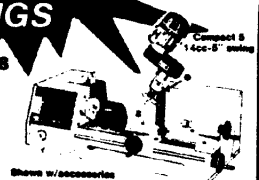
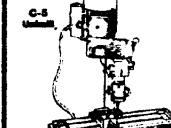

Special Needs - We will quote machinery and accessory package to fit your needs.

Lathe, Mill, Tap, Die, Metal (Brass, Aluminum, Steel, Machine Screws)